

**City of Schenectady  
Department of Engineering**

Room 205, City Hall, 105 Jay Street  
Schenectady, New York 12305-1938  
Office (518) 382-5082 Fax (518) 382-1050

Office Use Only				
Application No.:	_____			
Permit No.:	_____			
Date Issued:	_____			
Liability Insurance	Attached:	<input type="checkbox"/>	On File:	<input type="checkbox"/>

---

## WORK WITHIN CITY R-O-W PERMIT

---

**Instruction:**

This application shall be completed in full, either typed or printed **clearly** in ink, and filed with the City of Schenectady Department of Engineering, at the address above. Be sure to include all items listed in the checklist.

**Description:**

This permit is to allow and grant permission for utility or owner of infrastructure to perform work within or upon a city street or right-of-way for the benefit of the contractor or its' employer. This permit is not a contract for work to be paid by the City of Schenectady, and it is agreed that nothing herein contained shall be deemed or represented as such a contract or obligation.

All required information for the duties and responsibilities of permittee can be found herein and/or within the City of Schenectady's Municipal Code Book Section [§151-9 E. Deposit Required](#)

This Permit shall be allowed for a maximum of 6 months and require a fee depending on work that is to be performed ranging from **\$50.00-\$250.00+** that can be paid in City Hall 105 Jay Street Room 100, Schenectady, NY 12305.

All work within the City Right-of-way shall require submission of current liability insurance naming the City as additionally insured under the place held by the person(s) applying for permit.

---

**Part I: General Information**

1. Work Zone Information
  - a. Work Site Address: \_\_\_\_\_
  
2. Start Date and Time: \_\_\_\_\_
  
3. Total Days Required: \_\_\_\_\_
  
4. Applicant's Information
  - a. Applicant's Name: \_\_\_\_\_
  - b. Street Address: \_\_\_\_\_
  - c. City, State, ZIP: \_\_\_\_\_
  
5. Contractor's Name:
  - a. Street Address: \_\_\_\_\_
  - b. City, State, ZIP: \_\_\_\_\_
  - c. Telephone No.: \_\_\_\_\_
  - d. Emergency Name 24/7: \_\_\_\_\_
  - e. Emergency Phone #: \_\_\_\_\_

## Directions For Proper Application

1. General Directions:

Fill in the contents of the application as accurately as possible. Make sure to provide a number that can be contacted at all hours both the contractor's and the direct representative's. The schedule you provide should be as accurate as possible and if the work diverges from the timeline please contact the City of Schenectady's Department of Engineering./ To calculate the dimensions and square footage of the opening please refer to the checklist (last page). The following directions apply to the sketch and should be strictly adhered to for permit approval.

The sketch must include these items:

- Location (Street Address) of opening.
- Location of Disturbance(s).
- Dimensions of Disturbance(s).
- Show nearest intersecting street for reference.
- Show location of site features (utility poles, hydrants, manholes, valves, overhead utilities, underground utilities, buildings, driveways, curbs, sidewalks, etc).  
**Important:** Make sure to mark the sidewalk. If there are no sidewalks please state so on the sketch.
- Show restoration details.

1) General Information:

- a) Write location of excavation closest street address and or both streets if work is to be performed in an intersection.
- b) Write a brief description of why the excavation is taking place and what it is to accomplish. (i.e. gas lateral gas main, new service, etc.)
- c) Write the name of the owner of the property or cooperation that has requested the service, as well as their contact number.
- d) Write the name of contractor that will be performing the service on site, as well as the business contact information. Please include a 24/7 telephone number for emergency.
- e) Write the date and time when excavation is expected to start.
- f) Write the estimated duration of time for the work that is to be performed.
- g) List all outstanding temporary and permanent permits associated with the work being performed and the property requesting the work.

2) Disturbance Diagram:

- a) Write the appropriate section where and what size the excavation will be, with the approximate square footage.
- b) Sketch on page 3, a drawing showing the hole to be excavated (with size of hole written inside the hole), approximate distance from houses, nearest intersections, and or power poles.

3) Schedule of Restoration:

- a) Write expected date that work is to begin, and expected number of days to dig.
- b) Write expected date that the proposed work is to begin, and the number of days the work will take to complete.
- c) Write expected date that the backfill is to begin, and the number of days to fill in excavation.
- d) If work is being done between November 15th and April 1st, write expected date when the temporary restoration is to begin.
- e) Write expected date the permanent restoration is to begin, and the number of days to job completion.

4) Construction Methodology:

- a) Write a brief description of the planned method of compaction and backfill that are to be used, including the type of surface to be restored and the type off compaction equipment to be used.

## General Notes

- All pavement openings must be of rectangular or square shape; **NO IRREGULAR CUTS WILL BE PERMITTED.**
- All of the general specifications for a curb cut and materials to be used can be found in example drawings available from the City's Engineering Department.
- Sketches should be labeled as to if there is or is not a sidewalk present.
- All work shall conform to the applicable sections(s) of the city of Schenectady Code.

## Emergency Work

- Work may take place without a permit if it is an emergency but a permit must be filed for within 5 business days of the emergency. You must also contact the Engineering Department the day of the emergency to gain approval of the permit and to avoid extra fines concerning the lack of notification. If the emergency work is started during a time when the Engineering Office is closed the applicant must leave a message on the Engineering Office General Line (518) 382-5199 Ext 5082. The applicant must include in the message; time and date of starting work, location of work, type of emergency repair, duration of work, and name and 24 hour telephone number of the primary contact person.

## Temporary Permit Requirements

- The winter moratorium is November 1st to April 15th, during that time if there is an emergency a temporary permit may be issued.
- Temporary patches should be replaced with permanent ones by May 15th. If this timeline is not met a City engineering official must be contracted.
- Apply cold patch immediately after completion of backfill and compaction if concrete cannot be obtained at time of completion of work .
- Winter restoration should be done within one week of the cold patch placement.
- Cold patches should be replaced with a 4" minimum of concrete and bond breaker so that it level with the existing surface.

## Notification Requirements

- If the time constrain set by the permit (30 days) will knowingly not be met you must obtain special approval from the City of Schenectady.
- For emergency work; within 5 business day of permit issuance an installation update schedule should be provided.
- If any of the conditions or timelines granted by the permit are not met a city engineering official should be contracted.
- Notification should be given prior to:
  - Excavation
  - Backfill
  - Completing restoration both winter (in emergency situations during moratorium) and final restoration.

## Backfill and Compaction and Soft Surface Requirements

- Backfill should be reused or if it is not suitable; appropriate materials will be imported.
- Area will be left in rough grade condition absent of ruts and depressions.
- Compaction should be done in twelve inch (12") lifts Maximum to a minimum of 95% compaction of standard proctor or material used per lift.

**Part II: Disturbance Diagram**

1. Proposed Dimension of Opening(s)
  - a. Median area # of Openings:\_\_\_\_\_Total Square Footage:\_\_\_\_\_
  - b. Street area # of Openings:\_\_\_\_\_Total Square Footage:\_\_\_\_\_
  - c. Sidewalk area # of Openings:\_\_\_\_\_Total Square Footage:\_\_\_\_\_
  
2. Sketch Scope of work on Attached Disturbance Diagram (See Page 6)\*

\*All holes should be accounted for in Part II Section 1. If work consists of more than can be shown clearly on attached disturbance diagram, supply a map of all work and the surrounding area with road names, physical addresses and any other information that would be pertinent to describing work to be completed.

**Part III: Schedule of Restoration**

1. Proposed Excavation State Date:\_\_\_\_\_
2. Time to Complete Work:\_\_\_\_\_Days.
3. Time to Backfill All Holes:\_\_\_\_\_Days.
4. Temporary Restoration (November 1st - April 15th):  Yes  No
5. Permanent Restoration State Date:\_\_\_\_\_End Date:\_\_\_\_\_.

Notes\*: \_\_\_\_\_  
\_\_\_\_\_  
\_\_\_\_\_  
\_\_\_\_\_  
\_\_\_\_\_  
\_\_\_\_\_

\*Please note any expected delays during each time period and the reason for delay.

**Part IV: Construction Methodology**

1. Method of compaction and backfill, including the type of surface to be restored and the type of compaction equipment to be used:

---

---

---

---

---

---

**Part V: Signature of Understanding**

If, these permit conditions, including final restoration are not completed within the required length of time the undersigned must reapply for all applicable permits and pay all associated fees.

Any person, company, or business entity found not in compliance with this permit shall be subject to immediate revocation of permit privileges for the job being performed and suspension of all future work privileges until the job is brought into compliance. A stop-work order can be issued and recovery of the cost of materials, labor and inspection fees at prevailing rates can be charged to the undersigned to bring the job into compliance including forfeiture of any permit fee and/or deposit. In addition, for violation of the City of Schenectady Code section § 151, the undersigned will be guilty of a misdemeanor punishable by a fine not to exceed \$1,000 and/or 15 days in jail.

I, the undersigned, understand that the permit which may be issued pursuant to this application is done on the basis that all of the representations made on this permit application are true and accurate.

I understand that if any of the information given on this permit form is found to be untrue or inaccurate, or if the work initiated pursuant to a permit granted based on the representations made on this application, then the permit may be revoked without notice to myself, the contractor, or any other party.

I have read and understand all the provisions of the permit and shall comply with said requirements.

---

Applicant's Signature

---

Date

**PART II PERMIT APPLICATION SKETCH**

City of Schenectady, Dept. of Engineering  
City Hall, 105 Jay Street, Room 205  
Schenectady, NY 12305  
Ph. 518-382-5082 Fax. 518-382-1050

Applicant: \_\_\_\_\_

Street Address: \_\_\_\_\_

Phone Number: \_\_\_\_\_

Is there alternate side parking on street Yes  No

Notes/Comments:

**LOCATION OF WORK**



**\*\*\*PLEASE NOTE\*\*\***

- Show street name and house number.
- Show distance from curb face to building and from curb face to street side edge of proposed sidewalk.
- Show nearest Utility Pole and identify it by the affixed number.
- Draw a rough sketch of the proposed location and indicate sidewalk and driveway width and location where applicable.

**PART II PERMIT APPLICATION SKETCH**  
**SAMPLE**

City of Schenectady, Dept. of Engineering  
 City Hall, 105 Jay Street, Room 205  
 Schenectady, NY 12305  
 Ph. 518-382-5082 Fax. 518-382-1050

Applicant: JOHN SMITH

Street Address: 123 STATE STREET

Phone Number: (518) 123-4567

Is there alternate side parking on street Yes  No

Notes/Comments: Replace water service at 123 State St per City Specifications  
Closest Utility pole NG-45 in front of 125 State Street.

**LOCATION OF WORK**

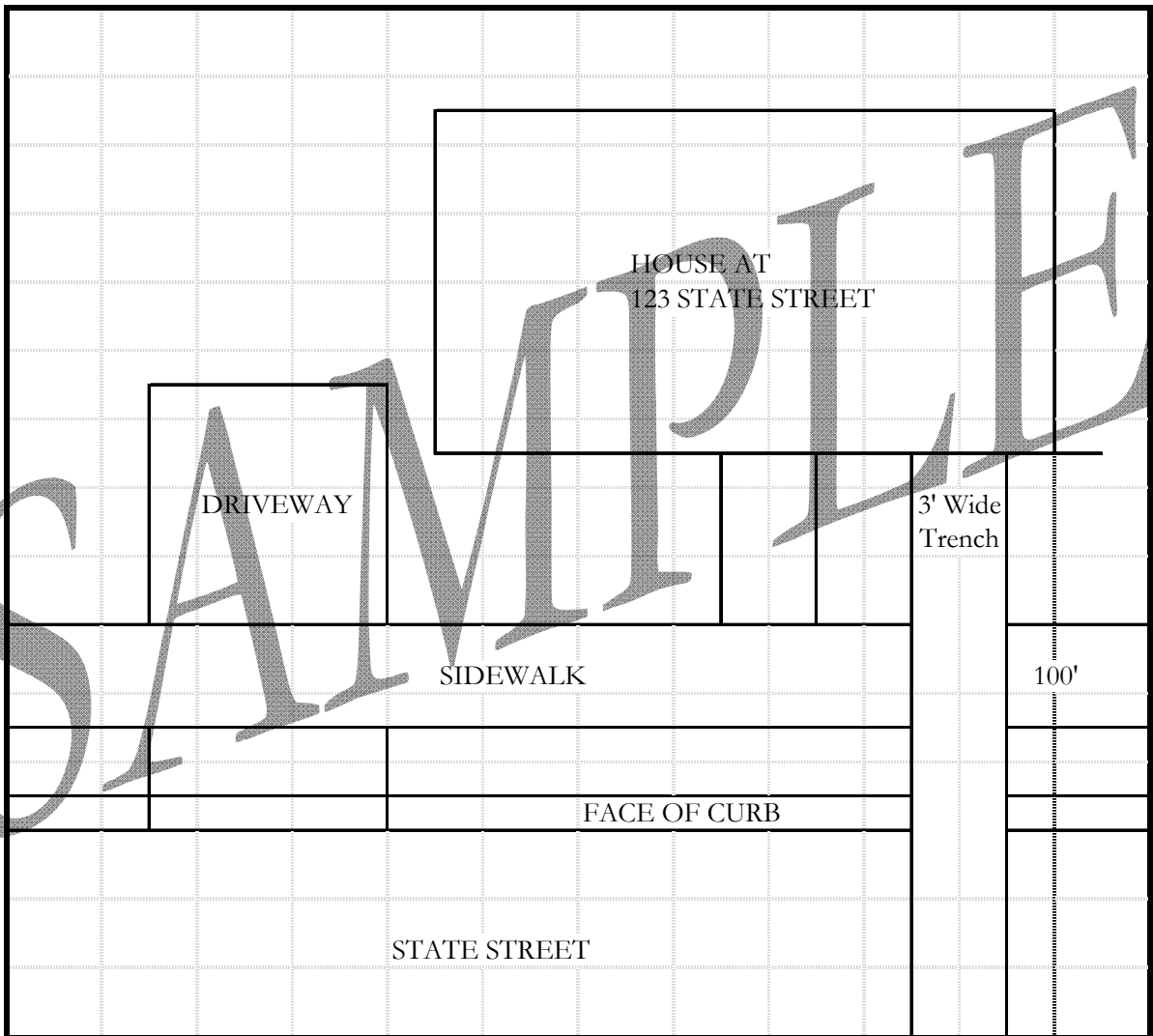

**\*\*\*PLEASE NOTE\*\*\***

- Show street name and house number.
- Show distance from curb face to building and from curb face to street side edge of proposed sidewalk.
- Show nearest Utility Pole and identify it by the affixed number.
- Draw a rough sketch of the proposed location and indicate sidewalk and driveway width and location where applicable.

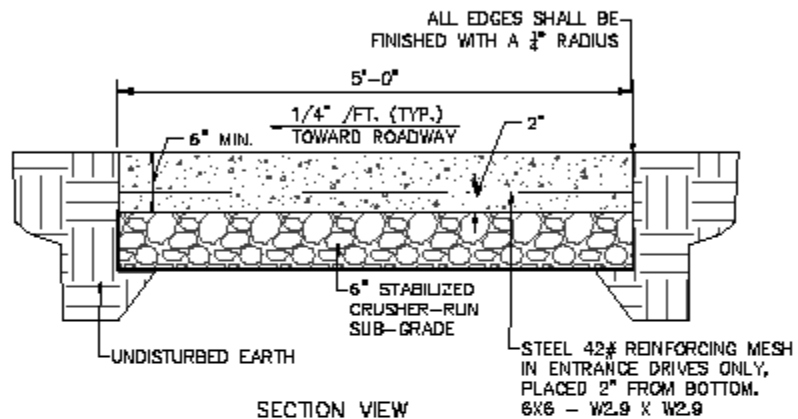

**NOTES:**

1. THE CONCRETE USED SHALL BE 4000 PSI PORTLAND CEMENT, AIR-ENTRAINED, CLASS "D" CONCRETE WITH AN AIR CONTENT OF 5% MIN., TO 7% MAX., AND A SLUMP OF TWO INCHES, MIN., TO THREE INCHES MAX..
2. ALL NEW CONCRETE SIDEWALKS SHALL BE TRANSVERSELY SCORED TO ONE (1) INCH DEPTHS, 5' INTERVALS. FULL-BEPTH CONSTRUCTION JOINTS SHALL BE PROVIDED AT ALL DRIVEWAY CROSSINGS OR AT 20' INTERVALS, MAX.
3. ALL CURBING SHALL BE RESET OR REPLACED IN KIND AS REQUIRED, CONSISTENT IN EVERY RESPECT WITH CITY SPECIFICATION.
4. A PROTECTIVE SEALER SHALL BE APPLIED OVER THE ENTIRE SIDEWALK TO PRODUCE A DURABLE WEARING SURFACE.

 CITY OF SCHENECTADY SCHENECTADY COUNTY, NEW YORK	MAYOR: GARY MOORHEAD	PROJECT NO.: SIDEWALK SPECIFICATIONS	SHEET TITLE: SIDEWALK DETAILS	LOGATOR: DRAWING NUMBER: G-001.1
	COMMISSIONER OF GENERAL SERVICES: CARL OLSEN	DESIGNED BY: PBK	DRAWN BY: PBK	SHEET NUMBER: 1 of 4
	CITY ENGINEER: CHRISTOPHER WALLER, P.E.	REVIEWED BY: CRW	APPROVED BY: CRW	SCALE: NOT TO SCALE
	DEPARTMENT OF ENGINEERING 105 JAY ST. ROOM 305 CITY HALL SCHENECTADY, NY 12305-1926	DATE: 4/28/2013		



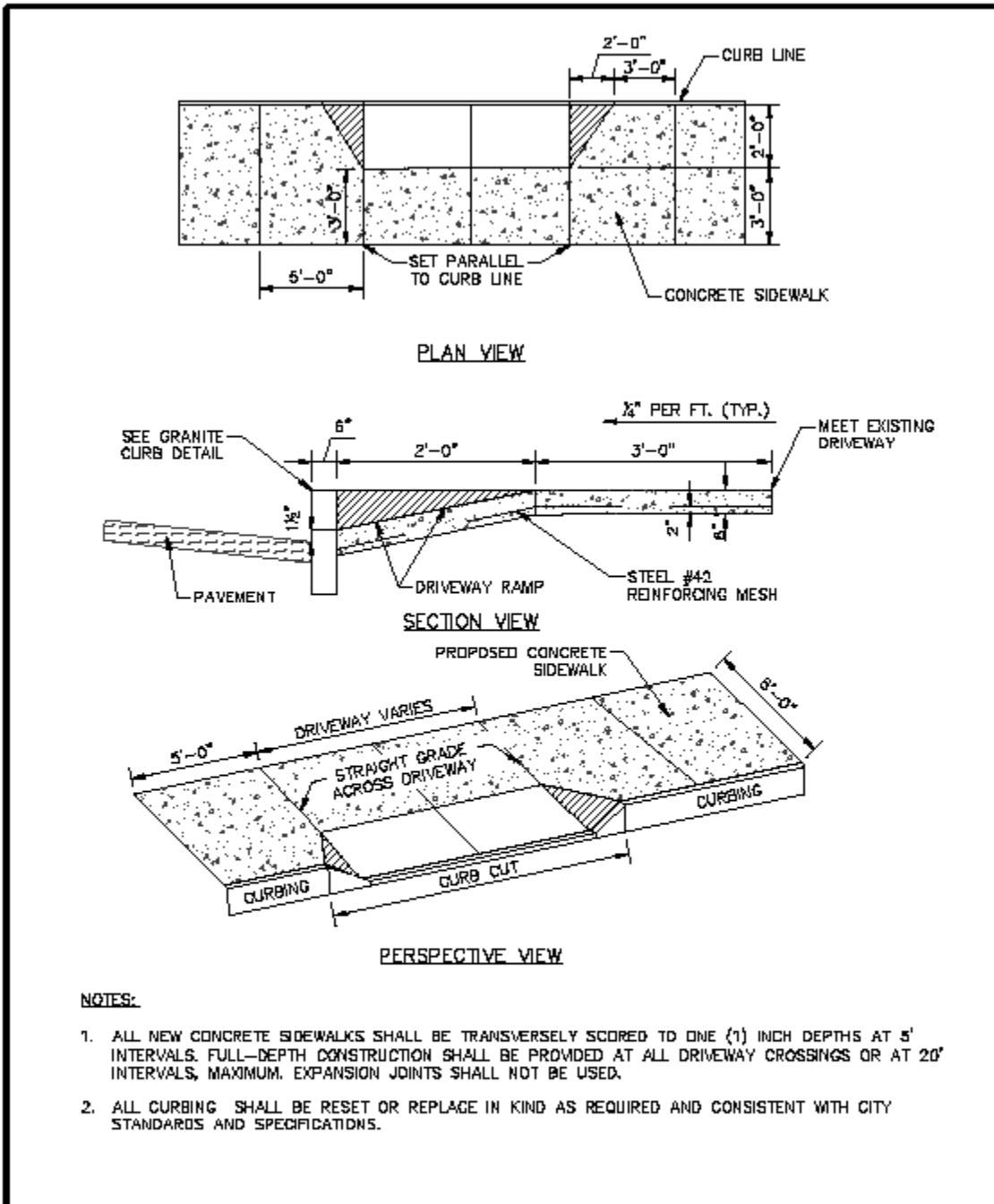

**NOTES:**

1. ALL NEW CONCRETE SIDEWALKS SHALL BE TRANSVERSELY SCORED TO ONE (1) INCH DEPTHS AT 5' INTERVALS. FULL-DEPTH CONSTRUCTION SHALL BE PROVIDED AT ALL DRIVEWAY CROSSINGS OR AT 20' INTERVALS, MAXIMUM. EXPANSION JOINTS SHALL NOT BE USED.
2. ALL CURBING SHALL BE RESET OR REPLAGE IN KIND AS REQUIRED AND CONSISTENT WITH CITY STANDARDS AND SPECIFICATIONS.

 CITY OF SCHENECTADY SCHENECTADY COUNTY, NEW YORK	NAME: GARY BOGARTY COMMISSIONER OF GENERAL SERVICES CARL OLSON	PROJECT NO.: DESIGNED BY: DRAWN BY: REVIEWED BY: APPROVED BY: DATE:	SIDEWALK SPECIFICATIONS PER PER DRW DRW 4/29/2013	SHEET TITLE: SIDEWALK NO BUFFER STRIP DETAILS SCALE: NOT TO SCALE	LOCATION: DRAWING NUMBER: G-001.2 SHEET NUMBER: 2 OF 4
	CITY ENGINEER: CHRISTOPHER WALKER, P.E. DEPARTMENT OF ENGINEERING 102 JAY ST. ROOM 305 CITY HALL SCHENECTADY, NY 12305-1606				

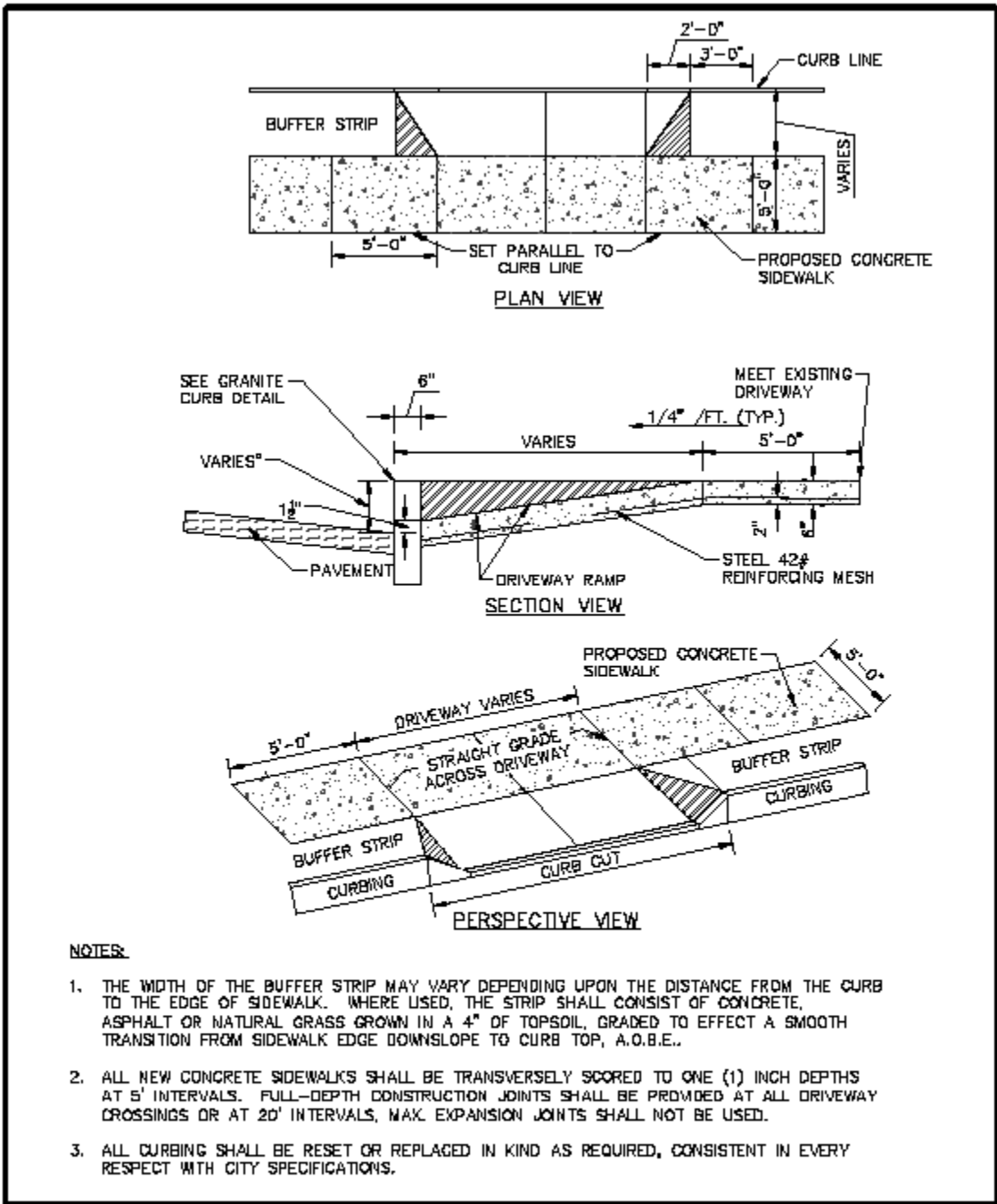

**NOTES:**

1. THE WIDTH OF THE BUFFER STRIP MAY VARY DEPENDING UPON THE DISTANCE FROM THE CURB TO THE EDGE OF SIDEWALK. WHERE USED, THE STRIP SHALL CONSIST OF CONCRETE, ASPHALT OR NATURAL GRASS GROWN IN A 4" OF TOPSOIL, GRADED TO EFFECT A SMOOTH TRANSITION FROM SIDEWALK EDGE DOWNSLOPE TO CURB TOP, A.O.B.E..
2. ALL NEW CONCRETE SIDEWALKS SHALL BE TRANSVERSELY SCORED TO ONE (1) INCH DEPTHS AT 5' INTERVALS. FULL-DEPTH CONSTRUCTION JOINTS SHALL BE PROVIDED AT ALL DRIVEWAY CROSSINGS OR AT 20' INTERVALS, MAX. EXPANSION JOINTS SHALL NOT BE USED.
3. ALL CURBING SHALL BE RESET OR REPLACED IN KIND AS REQUIRED, CONSISTENT IN EVERY RESPECT WITH CITY SPECIFICATIONS.

 CITY OF SCHENECTADY SCHENECTADY COUNTY, NEW YORK	SAUCE GARY WOODRUFF COMMISSIONER OF GENERAL SERVICES CHIEF CLERK CITY ENGINEER CHRISTOPHER WALLER, P.E. DEPARTMENT OF ENGINEERING 185 JAY ST. ROOM 205 CITY HALL SCHENECTADY, NY 12305-1658	PROJECT NO:1	SIDEWALK SPECIFICATIONS	SHEET TITLE	LOCATION:
		DESIGNED BY: FBK		SIDEWALK BUFFER STRIP DETAILS	DRAWING NUMBER: G-D01.3
		DRAWN BY: FBK		NOTES	SHEET NUMBER: 3 of 4
		REVIEWED BY: CRW		NOT TO SCALE	
		APPROVED BY: CRW			
		DATE: 4/28/2013			

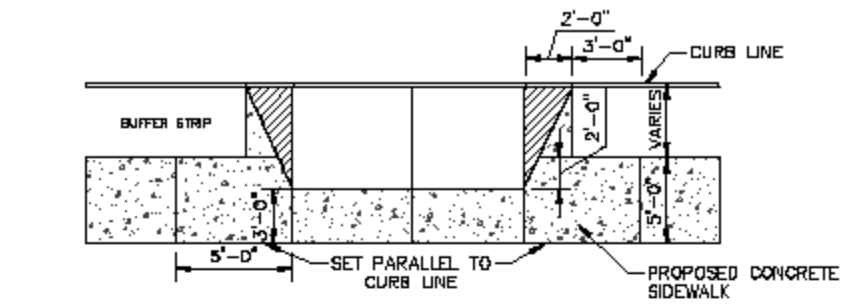

PLAN VIEW

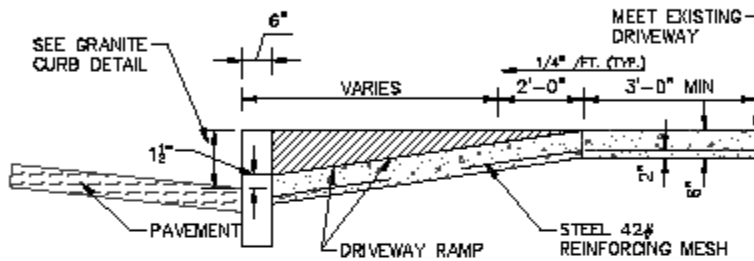

SECTION VIEW

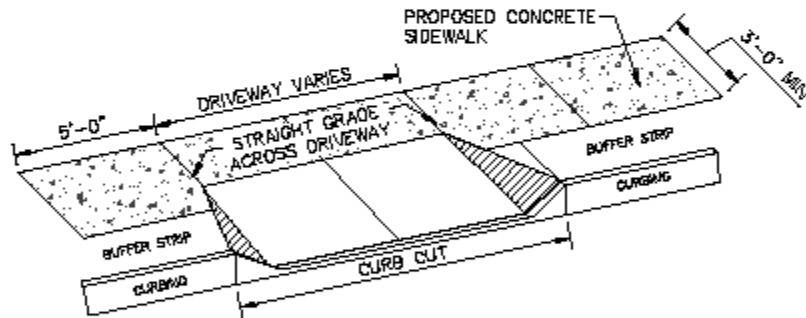

PERSPECTIVE VIEW

**NOTES:**

1. THE WIDTH OF THE BUFFER STRIP MAY VARY DEPENDING UPON THE DISTANCE FROM THE CURB TO THE FRONT EDGE OF SIDEWALK. WHERE USED, THE STRIP SHALL CONSIST OF CONCRETE, ASPHALT OR NATURAL GRASS GROWN IN A 4" OF TOPSOIL, GRADED TO EFFECT A SMOOTH TRANSITION FROM SIDEWALK EDGE DOWNSLOPE TO CURB TOP, A.D.B.E.
2. ALL NEW CONCRETE SIDEWALKS SHALL BE TRANSVERSELY SCORED TO ONE (1) INCH DEPTHS AT 5' INTERVALS. FULL-DEPTH CONSTRUCTION JOINTS SHALL BE PROVIDED AT ALL DRIVEWAY CROSSINGS OR AT 20' INTERVALS, MAX. EXPANSION JOINTS SHALL NOT BE USED.
3. ALL CURBING SHALL BE RESET OR REPLACED IN KIND AS REQUIRED, CONSISTENT IN EVERY RESPECT WITH CITY SPECIFICATION.



CITY OF SCHENECTADY  
SCHENECTADY COUNTY,  
NEW YORK

SAYOR:  
GARY MCCORMY  
COMMISSIONER OF GENERAL SERVICES  
CARL OLSER  
CITY ENGINEER:  
CHRISTOPHER WALKER, P.E.  
DEPARTMENT OF ENGINEERING  
155 JAY ST. ROOM 305 CITY HALL  
SCHENECTADY, NY 12305-1558

PROJECT NO.	SIDEWALK SPECIFICATIONS	SHEET TITLE:
DESIGNED BY	PBK	SIDEWALK NARROW BUFFER STRIP DETAILS
DRAWN BY	PBK	SCALE
REVIEWED BY	CRW	NOT TO SCALE
APPROVED BY	CRW	
DATE	4/29/2013	

LOCATION:
DRAWING NUMBER: G-001.4
SHEET NUMBER: 4 OF 4

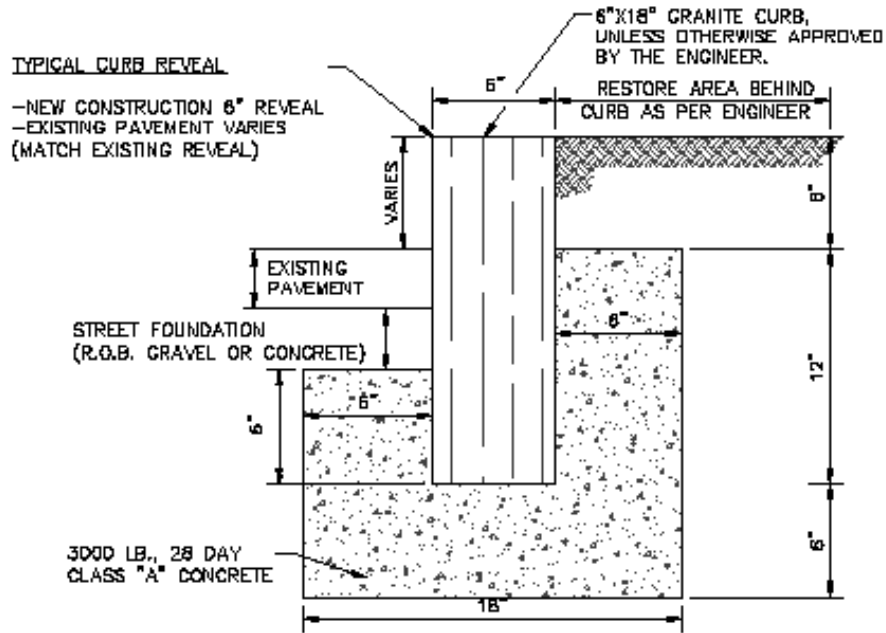

**NOTES:**

1. NEW CURBS SHALL BE SET TO PRODUCE A SMOOTH TRANSITION FROM EXISTING CURB TO EXISTING CURB A.O.B.E

 CITY OF SENECADAY SENECADAY COUNTY, NEW YORK	MAYOR GARY BOONSHAW	PROJECT NO.	GRANITE CURB INSTALL	SHEET TITLE	GRANITE CURB INSTALLATION	LOCATION DRAWING NUMBER G-002	
	COMMISSIONER OF GENERAL SERVICES CARL OLSEN	DESIGNED BY	PBK				SHEET NUMBER 1 OF 1
	CITY ENGINEER CHRISTOPHER TULLA, P.E.	DRAWN BY	PBK				
	DEPARTMENT OF ENGINEERING 100 JAY ST. ROOM 305 CITY HALL SENECADAY, NY 13858-1808	REVIEWED BY	GRW				
		APPROVED BY	GRW				
	DATE	4/29/2013			SCALE	NOT TO SCALE	

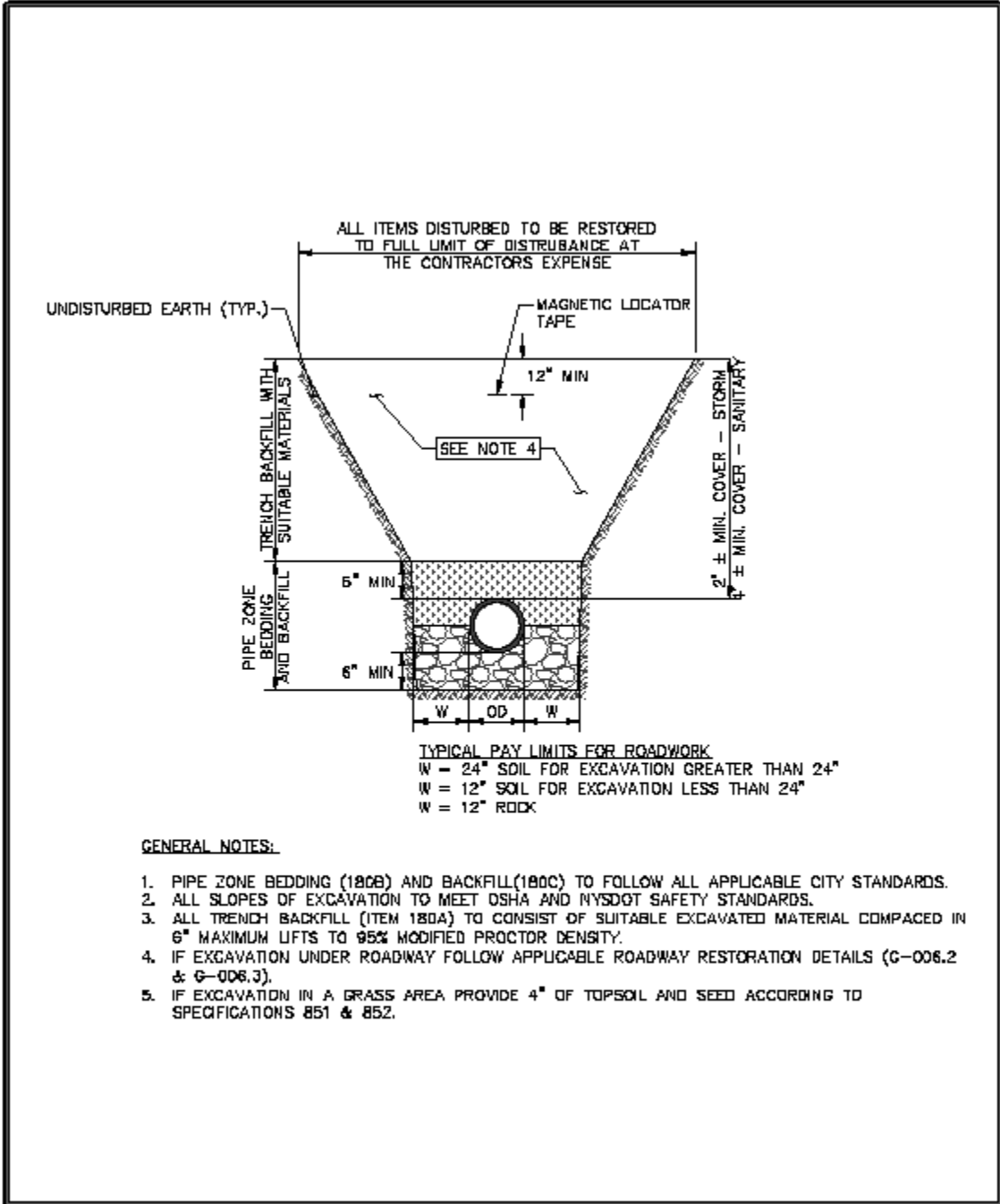

**GENERAL NOTES:**

1. PIPE ZONE BEDDING (180B) AND BACKFILL(180C) TO FOLLOW ALL APPLICABLE CITY STANDARDS.
2. ALL SLOPES OF EXCAVATION TO MEET OSHA AND NYSOBT SAFETY STANDARDS.
3. ALL TRENCH BACKFILL (ITEM 180A) TO CONSIST OF SUITABLE EXCAVATED MATERIAL COMPACTED IN 6" MAXIMUM LIFTS TO 95% MODIFIED PROCTOR DENSITY.
4. IF EXCAVATION UNDER ROADWAY FOLLOW APPLICABLE ROADWAY RESTORATION DETAILS (G-006.2 & G-006.3).
5. IF EXCAVATION IN A GRASS AREA PROVIDE 4" OF TOPSOIL AND SEED ACCORDING TO SPECIFICATIONS 851 & 852.

 CITY OF SCHENECTADY SCHENECTADY COUNTY, NEW YORK	SAVOR: GARY MCCORMY COMMISSIONER OF GENERAL SERVICES GARY OLSEN	PROJECT NO: TYPICAL TRENCH	SHEET TITLE: TYPICAL TRENCH EXCAVATION DETAIL	LOCATION: DRAWING NUMBER: G-006.1
	CITY ENGINEER: CHRISTOPHER WALLER, P.E.	DESIGNED BY: PBK	REVIEWED BY: CRW	SCALE: NOT TO SCALE
	DEPARTMENT OF ENGINEERING 105 JAY ST. ROOM 205 CITY HALL SCHENECTADY, NY 12305-1038	APPROVED BY: CRW	DATE: 4/29/2013	SHEET NUMBER: 1 of 3

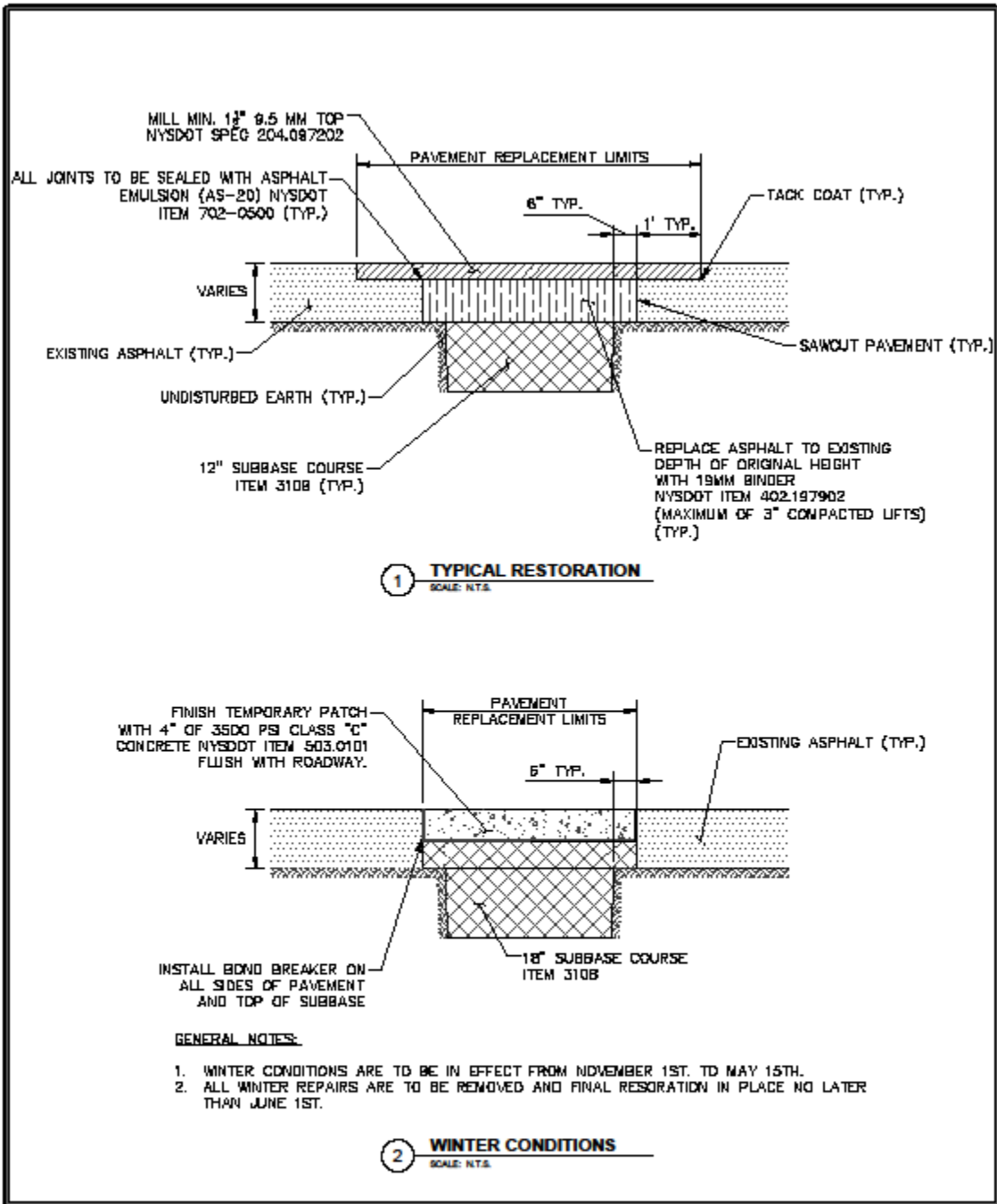

 CITY OF SCHENECTADY SCHENECTADY COUNTY, NEW YORK	MAYOR: GARY MCCORMY	PROJECT NO.: TYPICAL TRENCH	SHEET TITLE: ASPHALT RESTORATION - NO CONCRETE SUBBASE	LOCATION: DRAWING NUMBER: G-006.2
	COMMISSIONER OF GENERAL SERVICES: CARL OLSEN	DESIGNED BY: PBK	NOTES: NOT TO SCALE	SHEET NUMBER: 2 of 3
	CITY ENGINEER: CHRISTOPHER WALLER, P.E.	DRAWN BY: PBK		
	DEPARTMENT OF ENGINEERING 105 JAY ST. ROOM 305 CITY HALL SCHENECTADY, NY 12305-1038	REVIEWED BY: CRW	DATE: 4/29/2013	
		APPROVED BY: CRW		

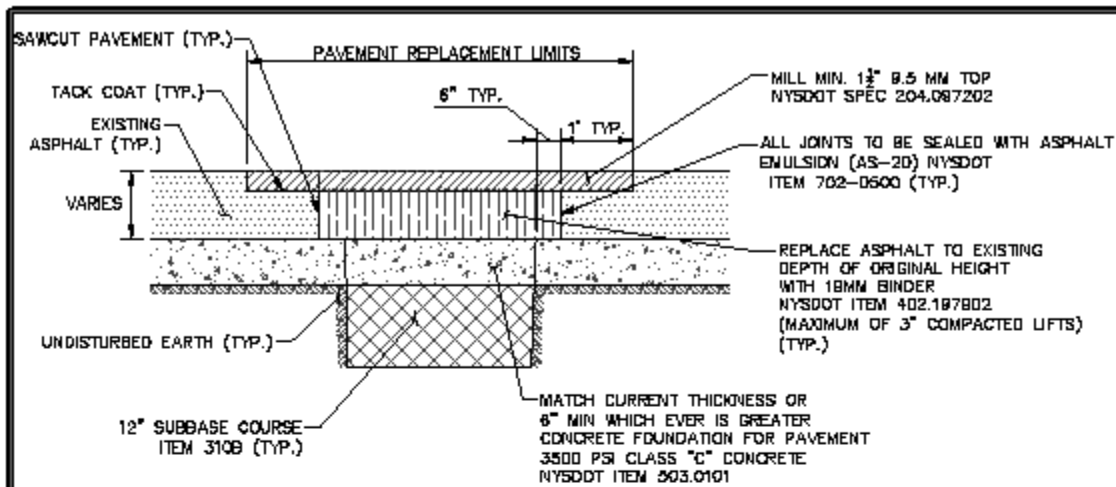

**1 TYPICAL RESTORATION**  
SCALE: N.T.S.

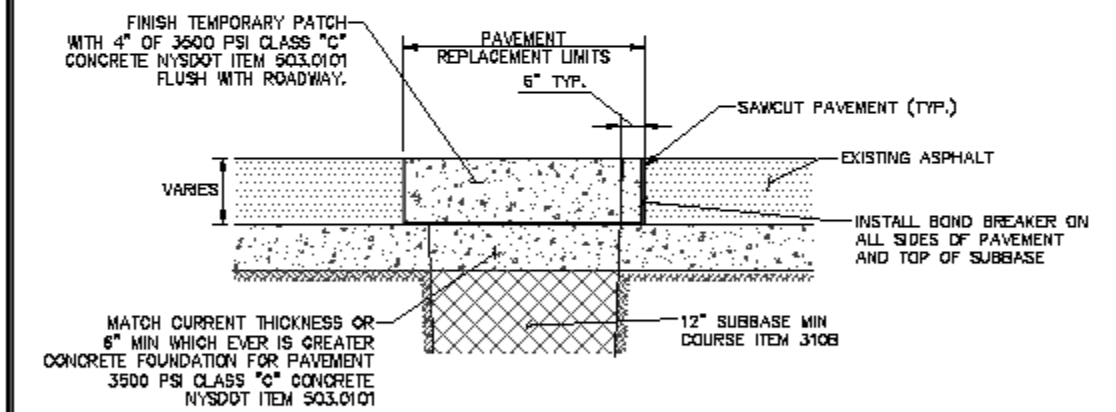

**GENERAL NOTES:**

1. WINTER CONDITIONS ARE TO BE IN EFFECT FROM NOVEMBER 1ST. TO MAY 15TH.
2. ALL WINTER REPAIRS ARE TO BE REMOVED AND FINAL RESORATION IN PLACE NO LATER THAN JUNE 15T.

**2 WINTER CONDITIONS**  
SCALE: N.T.S.

 CITY OF SCHENECTADY SCHENECTADY COUNTY, NEW YORK	MAYOR: GARY WOODRUFF COMMISSIONER OF GENERAL SERVICES: CARL OLSEN CITY ENGINEER: CHRISTOPHER WALLER, P.E. DEPARTMENT OF ENGINEERING 105 JAY ST. ROOM 205 CITY HALL SCHENECTADY, NY 12305-1638	PROJECT NO. TYPICAL TRENCH	SHEET TITLE:	LOCATION: DRAWING NUMBER: G-006.3 SHEET NUMBER: 3 of 3
		DESIGNED BY: PBK	ASPHALT RESTORATION - CONCRETE SUBBASE	
		DRAWN BY: PBK	NOTES:	
		REVIEWED BY: CRW	NOT TO SCALE	
APPROVED BY: CRW	DATE: 4/29/2013			

**ACORD** DATE (MM/DD/YYYY)  
09 13 2004  
**CERTIFICATE OF LIABILITY INSURANCE**

<b>PRODUCER</b>  <b>INSURED</b> JOHN & JANE DOE 000 ANY STREET ANY TOWN, ANY STATE 00000	THIS CERTIFICATE IS ISSUED AS A MATTER OF INFORMATION ONLY AND CONFERS NO RIGHTS UPON THE CERTIFICATE HOLDER. THIS CERTIFICATE DOES NOT AMEND, EXTEND OR ALTER THE COVERAGE AFFORDED BY THE POLICES BELOW.												
<table border="1" style="width: 100%; border-collapse: collapse;"> <tr> <th style="width: 80%;">INSURERS AFFORDING COVERAGE</th> <th style="width: 20%;">NAIC #</th> </tr> <tr> <td>INSURER A:</td> <td></td> </tr> <tr> <td>INSURER B:</td> <td></td> </tr> <tr> <td>INSURER C:</td> <td></td> </tr> <tr> <td>INSURER D:</td> <td></td> </tr> <tr> <td>INSURER E:</td> <td></td> </tr> </table>		INSURERS AFFORDING COVERAGE	NAIC #	INSURER A:		INSURER B:		INSURER C:		INSURER D:		INSURER E:	
INSURERS AFFORDING COVERAGE	NAIC #												
INSURER A:													
INSURER B:													
INSURER C:													
INSURER D:													
INSURER E:													

**COVERAGES**

THE POLICES OF INSURANCE LISTED BELOW HAVE BEEN ISSUED TO THE INSURED NAMES ABOVE FOR THE POLY PERIOD INDICATED, NOTWITHSTANDING ANY REQUIREMENT, TERM OR CONDITION OF ANY CONTRACT OR OTHER DOCUMENT WITH RESPECT TO WHICH THIS CERTIFICATE MAY BE ISSUED OR MAY PERTAIN, THE INSURANCE AFFORDED BY THE POLICIES DESCRIBED HEREIN IS SUBJECT TO ALL THE TERMS, EXCLUSIONS, AND CONDITIONS OF SUCH POLICES. AGGREGATES LIMITS SHOWN MAY HAVE BEEN REDUCED BY PAID CLAIMS.

INSR. LTR	TYPE OF INSURANCE	POLICY NUMBER	POLICY EFFECTIVE DATE (MM/DD/YYYY)	POLICY EXPIRATION	LIMITS
A	GENERAL LIABILITY <input type="checkbox"/> COMMERCIAL GENERAL LIABILITY <input type="checkbox"/> CLAIMS MADE <input type="checkbox"/> OCCUR <input type="checkbox"/> <input type="checkbox"/> GEN'L AGGREGATE LIMIT APPLIES PER: <input type="checkbox"/> POLICY <input type="checkbox"/> PRODUCT <input type="checkbox"/> LOC				EACH OCCURANCE            \$ 1,000,000.00 FIRE DAMAGE (Any one fire)    \$ - MED EXP (Any one person)    \$ - PERSONAL & ADV INIURY    \$ - GENERAL AGGRREGATE    \$ 2,000,000.00 PRODUCTS-COMP/OP AGG    \$ -
A	AUTOMOBILE LIABILITY <input type="checkbox"/> ANY AUTO <input type="checkbox"/> ALL OWNED AUTOS <input type="checkbox"/> SCHEDULED AUTOS <input type="checkbox"/> HIRED AUTOS <input type="checkbox"/> NON-OWNED AUTOS <input type="checkbox"/>	SAMPLE			COMBINED SINGLE LIMIT (Ea accident)    \$ - BODILY INIURY (Per person)    \$ - BODILY INIURY (Per person)    \$ - PROPERTY DAMAGE (per accident)    \$ 500,000.00
	GARAGE LIABILITY <input type="checkbox"/> ANY AUTO <input type="checkbox"/>	SAMPLE			AUTO ONLY - EA ACCIDENT    \$ - OTHER THAN EA ACC    \$ - AUTO ONLY AGG    \$ -
	EXCESS/UMBRELLA LIABILITY <input type="checkbox"/> OCCUR <input type="checkbox"/> CLAIMS MADE <input type="checkbox"/> DEDUCTIBLE <input type="checkbox"/> RETENTION \$				EACH OCCURANCE            \$ 250,000.00 AGGREGATE                    \$ - \$ - \$ -
	WORKERS COMPENSATION AND EMPLOYERS' LIABILITY				<input type="checkbox"/> WO STATU- <input type="checkbox"/> OTHER TORY LIMITS E.L. EACH ACCIDENT E.L. DISEASE - EA EMPLOYEE E.L. DISEASE - POLICY LIMIT

DESCRIPTION OF OPERATIONS/LOCATIONS/VEHICLES/EXCLUSIONS ADDED BY ENDORSEMENT/ SPECIAL PROVISIONS  
 THE CITY OF SCHENECTADY IS ADDITIONALLY INSURED

<b>CERTIFICATE HOLDER</b>  City of Schenectady 105 Jay St, Room #205 NY 12305	<b>CANCELLATION</b>  SHOULD ANY OF THE ABOVE DESCRIBED POLICES BE CANCELLED BEFORE THE EXPIRATION DATE THEREOF, THE ISSUING COMPANY WILL ENDEAVOR TO MAIL 30 DAYS WRITTEN NOTICE TO THE CERTIFICATE HOLDER NAMED TO THE LEFT, BUT FAILURE TO DO SO SHALL IMPOSE NO OBLIGATION OR LIABILITY OF ANY KIND UPON THE INSURER, IT'S AGENTS OR REPRESENTATIVE. AUTHORIZED REPRESENTATIVE
---	--