

NOTES:

1. THE CONCRETE USED SHALL BE 4000 PSI PORTLAND CEMENT, AIR-ENTRAINED, CLASS "D" CONCRETE WITH AN AIR CONTENT OF 5%, MIN., TO 7%, MAX., AND A SLUMP OF TWO INCHES, MIN., TO THREE INCHES MAX.,
2. ALL NEW CONCRETE SIDEWALKS SHALL BE TRANSVERSELY SCORED TO ONE (1) INCH DEPTHS. 5' INTERVALS. FULL-DEPTH CONSTRUCTION JOINTS SHALL BE PROVIDED AT ALL DRIVEWAY CROSSINGS OR AT 20' INTERVALS, MAX.
3. ALL CURBING SHALL BE RESET OR REPLACED IN KIND AS REQUIRED, CONSISTENT IN EVERY RESPECT WITH CITY SPECIFICATION.
4. A PROTECTIVE SEALER SHALL BE APPLIED OVER THE ENTIRE SIDEWALK TO PRODUCE A DURABLE WEARING SURFACE.



CITY OF SCHENECTADY
SCHENECTADY COUNTY,
NEW YORK

MAYOR:
GARY MCCARTHY
COMMISSIONER OF GENERAL SERVICES:
CARL OLSEN

CITY ENGINEER:
CHRISTOPHER WALLIN, P.E.

DEPARTMENT OF ENGINEERING
105 JAY ST, ROOM 205 CITY HALL
SCHENECTADY, NY 12305-1938

PROJECT NO.: SIDEWALK SPECIFICATIONS

DESIGNED BY: PBK

DRAWN BY: PBK

REVIEWED BY: CRW

APPROVED BY: CRW

DATE: 4/29/2013

SHEET TITLE:

SIDEWALK DETAILS

SCALE:

NOT TO SCALE

LOCATION:

DRAWING NUMBER:

G-001.1

SHEET NUMBER:

1 OF 4

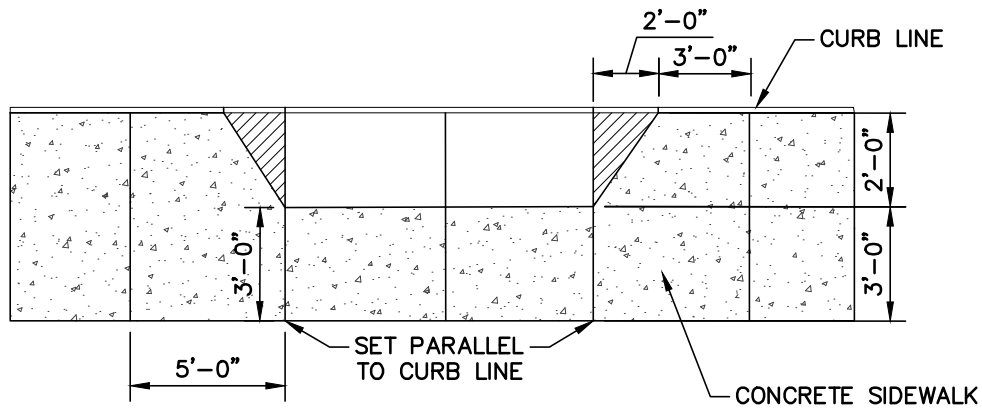

PLAN VIEW

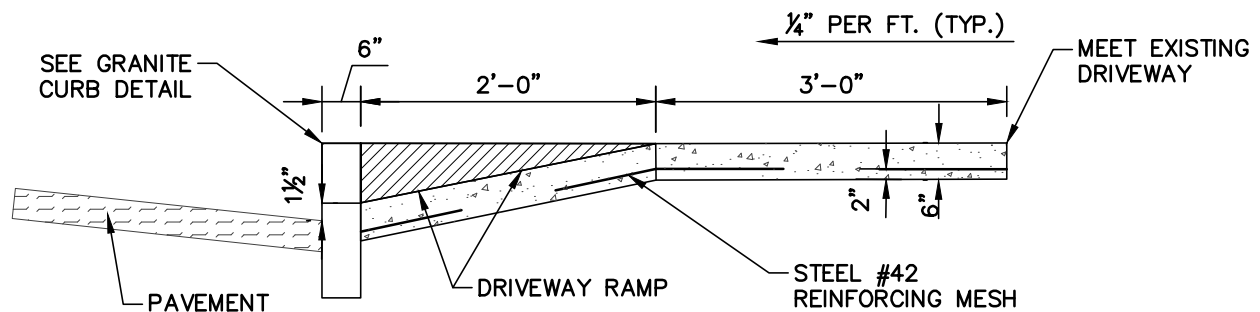

SECTION VIEW

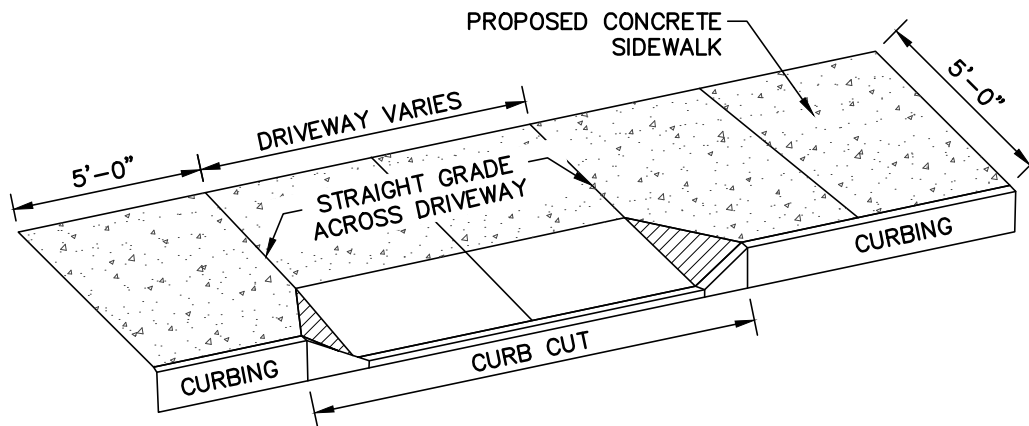

PERSPECTIVE VIEW

NOTES:

1. ALL NEW CONCRETE SIDEWALKS SHALL BE TRANSVERSELY SCORED TO ONE (1) INCH DEPTHS AT 5' INTERVALS. FULL-DEPTH CONSTRUCTION SHALL BE PROVIDED AT ALL DRIVEWAY CROSSINGS OR AT 20' INTERVALS, MAXIMUM. EXPANSION JOINTS SHALL NOT BE USED.
2. ALL CURBING SHALL BE RESET OR REPLACE IN KIND AS REQUIRED AND CONSISTENT WITH CITY STANDARDS AND SPECIFICATIONS.

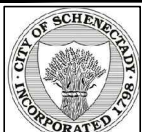

CITY OF SCHENECTADY
SCHENECTADY COUNTY,
NEW YORK

MAYOR:
GARY MCCARTHY
COMMISSIONER OF GENERAL SERVICES:
CARL OLSEN
CITY ENGINEER:
CHRISTOPHER WALLIN, P.E.

DEPARTMENT OF ENGINEERING
105 JAY ST. ROOM 205 CITY HALL
SCHENECTADY, NY 12305-1938

PROJECT NO.:	SIDEWALK SPECIFICATIONS
DESIGNED BY:	PBK
DRAWN BY:	PBK
REVIEWED BY:	CRW
APPROVED BY:	CRW
DATE:	4/29/2013

SHEET TITLE:	SIDEWALK NO BUFFER STRIP DETAILS
SCALE:	NOT TO SCALE

LOCATION:	
DRAWING NUMBER:	G-001.2
SHEET NUMBER:	2 OF 4

